

FLEXMASTER CANADA® 

Platinum Flow® Duct System





LEED Smart Platinum Flow[®] Duct System



Platinum Flow[®] System Design

The Platinum Flow[®] System is a **LEED (Leadership in Energy Efficient Design) inspired Duct System** designed to save time and money for building owners, engineers, installers and end users alike. The cornerstone design feature of the system is the double fail safe EPDM sealing gasket which is mechanically locked with a continuous 360° hem. This unique design allows for quick site assembly and a tight seal without the use of field applied sealants. During installation as contact is made, the double seals fold over the mating duct producing an exceptionally tight seal.



Today's modern building envelope demands increased efficiencies throughout all construction elements. Platinum Flow[®] delivers with both an energy efficient design and factory controlled construction.

Technical Data

Duct Options and Materials

Platinum Flow[®] is available in single wall and double wall configurations. Double wall pipe can be supplied with solid cores for thermal applications or perforated cores for acoustic applications.

Construction

Unless otherwise noted, all Platinum Flow[®] pipe and fittings shall be constructed in accordance with the latest SMACNA Duct Construction Standard to +10" water column working pressure.

Material Options

Galvanized and Satin Coat steel conforming to ASTM A653 and A924. Stainless steel 304 and 316L conforming to ASTM A240.

Air Leakage Performance

Platinum Flow[®] System is guaranteed to meet SMACNA's Leakage Class 3 and complies with ASHRAE 90.1-2004 section 6.4.4.2.2.

Fire Rating

EPDM air seal gasket; flame spread 0, smoke developed 5 in accordance with ASTM standard E84-91a.

Flexmaster Canada Limited has proudly supplied superior HVAC products to the construction industry for more than 40 years. The extensive range of specified products offer numerous value-added features & benefits. All Flexmaster products are warranted to be free from all defects in material and workmanship. It is impossible to test Flexmaster products under all conditions to which they might be subjected in the field. It is therefore the buyer and/or end users' responsibility to test all Flexmaster products under conditions that duplicate the service conditions prior to installation. Shipping Terms: F.O.B. Our Warehouses. Due to continuous improvements, all specifications are subject to change without prior notice.



Sleek Design, Optimal Performance

- Full body conical tees, full radius elbows and long transitions provide ideal air flow and appeal
- To reduce static pressure loss, wherever possible hard tool formed fittings are used, allowing constant air flow throughout the system
- All longitudinal joints are continuously resistance welded to prevent system pressure loss. All other seams are internally sealed
- To optimize best system performance and appearance, field installed saddle taps are not recommended

Key Design Feature

Factory controlled, close tolerance, calibrated, product construction standards which ensure consistency in manufacturing of the Platinum Flow® System. EPDM factory installed gaskets are ozone and UV resistant and withstand normal operating temperatures from -40°F to 250°F (-40°C to +120°C)

Quality Assurance

Our quality system includes in-coming raw material inspection, in process inspection and continuous improvement initiatives. To ensure consistent product quality, Platinum Flow® System pipe and fittings are calibrated to our engineered shop standards.



Significant Advantages of the Platinum Flow System

- Innovative energy efficient design
- Quick assembly
- Fittings can be rotated during assembly
- Suitable for all climates -40°F to 250°F (-40°C to +120°C)
- Pressure tested to 12" w.c. (3000 Pa) positive and negative pressure
- No field applied sealants required

SMACNA Leakage Class 3 Certified

The Platinum Flow® System has been tested by an independent NEBB (National Environmental Balancing Bureau) Certified Test Lab to SMACNA's HVAC air duct leakage test standards.

Test results show that the Platinum Flow® System well exceeds the stringent requirements of SMACNA Leakage Class 3.



Flexmaster Platinum Flow® Single Wall Round Specification

All round supply, return and exhaust duct work shall be Flexmaster Platinum Flow® as manufactured by Flexmaster Canada Limited (905-731-9411). The duct system shall consist of fittings and dampers that are factory fitted with a sealing gasket and spiral duct which, when installed according to the manufacturer's instructions, will seal the duct joints without the use of duct sealer. Saddle taps are not permitted. Any branch ducts must be factory built and installed as full body tees.



Flexmaster Platinum Flow® Double Wall Round Specification

All round supply, return and exhaust duct work shown on the plans or indicated in the project specification to be insulated shall be Flexmaster Platinum Flow® Double Wall as manufactured by Flexmaster Canada Limited (905-731-9411). The duct system shall consist of fittings & dampers that are factory fitted with a sealing gasket and spiral duct which, when installed according to the manufacturer's instructions, will seal the duct joints without the use of duct sealer. Saddle taps are not permitted. Any branch ducts must be factory built and installed as full body tees.

Ductwork System

- Platinum Flow Single Wall Round Platinum Flow Double Wall Round

Construction

Unless otherwise noted, the gauge for all ductwork will be constructed in accordance with the latest SMACNA HVAC Duct Construction Standard to +10 inch wg.

Air Leakage Performance

Flexmaster guarantees to meet SMACNA's Leakage Class 3 and complies with ASHRAE 90.1-2004 section 6.4.4.2.2 Round Duct without the application of external sealants or the use of flanges.

Spiral Pipe

All round spiral pipe is certified to Flexmaster's shop standards
Spiral pipe slippage is prevented by means of a flat seam (SMACNA type RL1) and mechanically formed indentation evenly spaced along the spiral seam.



Fittings

Manufactured using one or more of the following construction methods:

- *Overlapped edges are stitched or spot welded along the entire length of the fitting*
- *Standing seam gore locked and internally sealed*
- *Button punched and internally sealed*
- *Elbows 5" through 12" diameter will be die stamped and continuously stitched welded.*

Material - Ductwork will be fabricated from:

- Standard galvanized steel meeting ASTM A653 and A924
- Optional 304L stainless steel conforming to ASTM A240 2B finish
- Optional 316L stainless steel conforming to ASTM A240 2B finish

End Connection

- Round Duct "self-sealing" (single wall and double wall round only):
- All spiral pipe and fitting ends, up to and including 50 inch diameter, is certified to Flexmaster's shop standards
- All fitting ends from 5 inch to 50 inch diameter have rolled edges for added strength and rigidity
- All fitting ends have a factory installed double Fail Safe™ gasket
- Gasket is mechanically attached to the fitting using 180° hemmed edge
- Flame Spread = 0 and Smoke Developed = 5 in accordance with ASTM std. E84-91a EPDM gasket rated -40°F to 250°F (-40°C to +120°C)

Platinum Flow Submittal and Specifications

Single Wall Round Assembly Instructions

Preparations for Assembly

- Check that all ductwork to be used in the system is Flexmaster Round Duct and is undamaged. All Flexmaster Round Duct fittings must be used with approved spiral pipe certified by Flexmaster Canada Limited.
- Do not use any ductwork that has been damaged in such a way that it may jeopardize the air tightness or structural strength of the system.
- Store all ductwork in a well organized and weather proof storage area to minimize the risk of damage.
- Cut all spiral pipe at right angles and carefully remove any burrs from the cut edges. Installation is easier and the risk of damaging the gasket is reduced if there are no burrs.

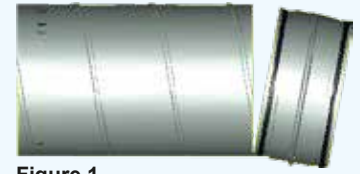

Figure 1

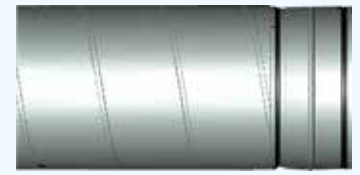

Figure 2



Figure 3

Assembly

1. Start by inserting the gasketed end of the fitting into the spiral pipe (*figure 1*).
2. Check that the gasket is in full contact with the inside of the spiral pipe all the way around so that the lip is not twisted in one direction or the other. (*figure 2*).
3. Fully insert gasketed end of fitting into the spiral pipe until it meets bead of the fitting. Turning the fitting will aid both insertion and removal (*figure 3*).
4. Secure the fitting in the spiral pipe using self-tapping screws or airtight pop rivets. Recommended quantities and sizes to be used are shown in the table below.

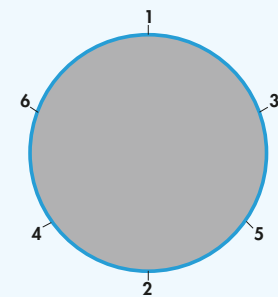

Figure 4

Spiral Pipe Dia (in)	Screw Size	Quantity
5-10	$\frac{1}{8} \times \frac{1}{2}$	3
12-24	$\frac{1}{8} \times \frac{1}{2}$	4
26-50	$\frac{1}{8} \times \frac{1}{2}$	6

Do not use more fasteners than specified.

5. Fasteners should be positioned $\frac{1}{2}$ inch from the bead to prevent damage to the gasket (*figure 3*).
6. Placement of the fastening screws should be opposite from one another evenly spaced around the circumference, much like the procedure for tightening lug nuts on a tire. (*figure 4*)



Flexmaster Platinum Flow® Double Wall Round

Inner and outer spiral pipe will be of spiral lock seam construction and furnished with a recessed inner liner and insulation stop. The inner liner will be flushed with the outer shell and will utilize an insulation stop for thermal integrity and to simplify installation.

All ductwork size dimensions refer to the air side. In addition, the ductwork pressure seal is always on the outer shell. The outer shell connection will be a Round Duct connection meeting all of the same leakage criteria as single wall round ductwork system.

Double Wall System

Standard thermal double wall ductwork system consists of a solid inner liner on the spiral pipe, a solid inner liner on the fittings, a layer of glass fiber insulation, and a solid outer pressure shell. Optional perforated inner liner is available for acoustical applications. For standard 1 inch insulation, the outer pressure shell diameter will be 2 inches larger than the inner liner. For the optional 2 inch insulation, the outer pressure shell diameter will be 4 inches larger than the inner liner.

Materials

- Solid inner liner is used for spiral pipe and fittings
- Perforated inner liner has $\frac{3}{32}$ inch perforations on $\frac{3}{16}$ inch staggered centers corresponding to an overall open area of 23%
- Standard 1 inch glass fiber insulation has a maximum conductivity factor (k) of 0.29 BTU-in/hr x ft² x °F at 75°F mean ambient temperature (R = 4.2)
- Retaining fabric is 8 mil, 1.27 O.S.Y. weight, spun bond polyester with an air permeability rate of 591 cfm/ft²/per min.
- Insulation stop is a closed-cell elastomeric foam with a maximum conductivity factor (k) of 0.23 BTU-in/hr x ft² x 5°F and an operating temperature of -90°F to +180°F. (Available in 1 inch and 2 inch Double Wall Round).



Platinum Flow® Double Wall Options

- | | | |
|--------------|--|--|
| Insulation: | <input type="checkbox"/> 1 inch standard (R = 4.2) | <input type="checkbox"/> 2 inch (R = 8) |
| Inner Liner: | <input type="checkbox"/> Solid Spiral Pipe | <input type="checkbox"/> Solid Fitting |
| | <input type="checkbox"/> Perforated Spiral Pipe | <input type="checkbox"/> Perforated Fittings |

Platinum Flow Submittal and Specifications

Double Wall Round Assembly Instructions

Preparations for Assembly

- Check that all ductwork to be used in the system is Flexmaster Round Duct and is undamaged. All Flexmaster Round Duct fittings must be used with approved spiral pipe certified by Flexmaster Canada Limited.
- Do not use any ductwork that has been damaged in such a way that it may jeopardize the air tightness or structural strength of the system.
- Store all ductwork in a well organized and weather proof storage area to minimize the risk of damage.
- Cut all spiral pipe at right angles and carefully remove any burrs from the cut edges. Installation is easier and the risk of damaging the gasket is reduced if there are no burrs.
- For preparing field cut double wall duct for connection with a fitting, use a field cut adapter. (PFDA)

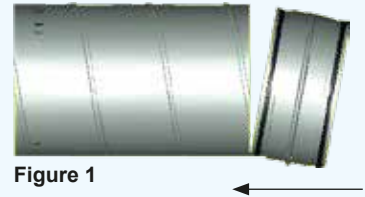

Figure 1

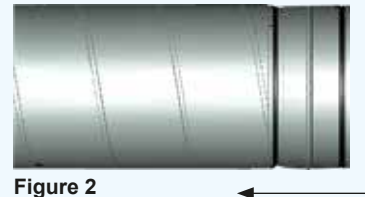

Figure 2



Figure 3

Assembly

1. Start by inserting the gasketed end of the fitting into the spiral pipe (*figure 1*).
2. Check that the gasket is in full contact with the inside of the spiral pipe all the way around so that the lip is not twisted in one direction or the other. (*figure 2*).
3. Fully insert gasketed end of fitting into the spiral pipe until it meets bead of the fitting. Turning the fitting will aid both insertion and removal (*figure 3*).
4. Secure the fitting in the spiral pipe using self-tapping screws or airtight pop rivets. Recommended quantities and sizes to be used are shown in the table below.

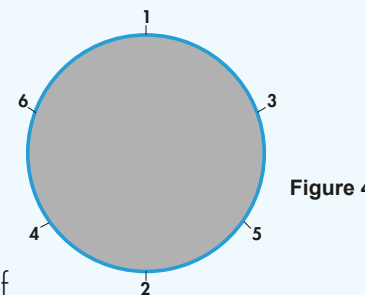

Figure 4

Spiral Pipe Dia (in)	Screw Size	Quantity
5-10	1/8 x 7/8	3
12-24	1/8 x 7/8	4
26-50	1/8 x 7/8	6

Do not use more fasteners than specified.

5. Fasteners should be positioned 1/2 inch from the bead to prevent damage to the gasket (*figure 3*).
6. Placement of the fastening screws should be opposite from one another evenly spaced around the circumference, much like the procedure for tightening lug nuts on a tire. (*figure 4*)

Two Piece Stamped Elbows

Pressed elbows and angles are resistance welded with copper on both the heel and throat. All pressed fittings are manufactured from extra deep drawing steel (EDDS) in accordance with ASTM-A653. Pressed fittings are precision drawn, tolerances must be within + or - .002 thickness to assure a quality product at all times.

All pressed fittings are made of 24 Ga. or 22 Ga.

Galvanized material with a G60 or better coating thickness and are chemically treated to retard white rust.

Centerline Throat Radius Chart

Diam.	90°	45°
3"	4½"	4½"
4"	6"	6"
5"	7½"	7½"
6"	9"	9"
7"	10½"	10½"
8"	12"	12"
9"	13½"	13½"
10"	15"	15"
12"	18"	18"
14"	21"	21"



1PFE145 $\frac{A}{A}$

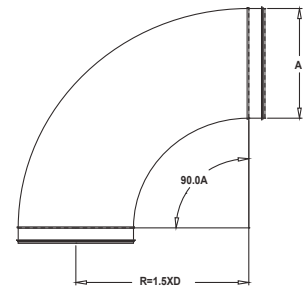
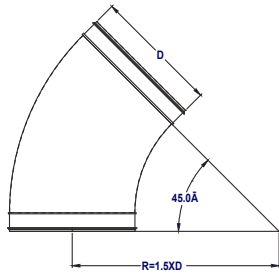

1PFE190 $\frac{A}{A}$

Standing Seam Fabricated Elbows

These are available from 6" through 50" diameters. Other angles and throat radiuses are available.

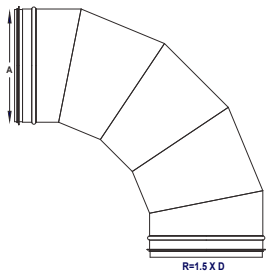

1PFE590 $\frac{A}{A}$
R=1½ x D

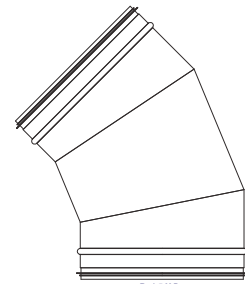

1PFE345 $\frac{A}{A}$
R=1½ x D

Platinum Flow Specifications

90° Tee

Dimensions to be listed as follows:
A, B, C. $L = "C" + 4"$

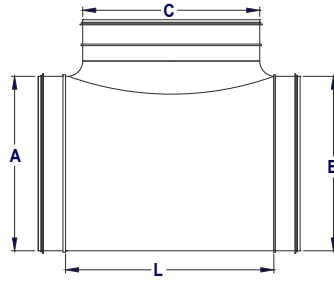

1PFT
A C



Tee with Reducer

Dimensions to be listed as follows:
A, B, C. $L = "C" + 4"$

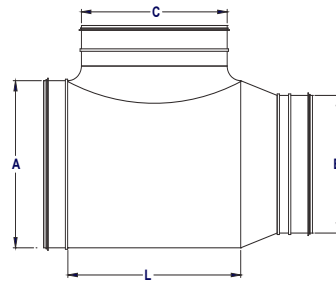

1PFTR
A B C



Cross

Dimensions to be listed as follows: A, B,
C, D. $L = \text{largest of "C" or "D"} + 4"$

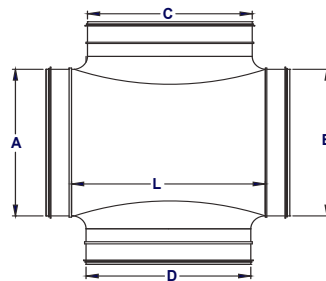

1PFC
A C D



Cross with Reducer

Dimensions to be listed as follows: A, B,
C, D. $L = \text{largest of "C" or "D"} + 4"$

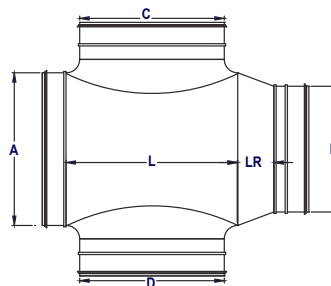

1PFCR
A B C D



Conical Tee

Dimensions to be listed as follows: A, B, C L = C + 5"

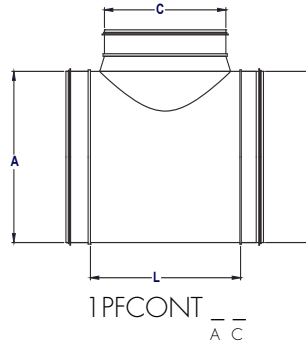

Conical Tee with Reducer

Dimensions to be listed as follows: A, B, C L = C + 5"

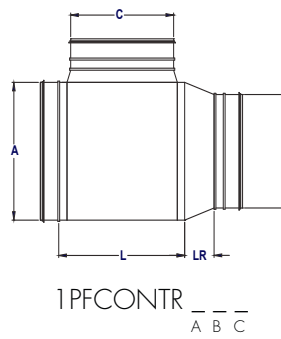

Conical Cross

Dimensions to be listed as follows: A, B, C, D L = Larger of "C" or "D" + 5"

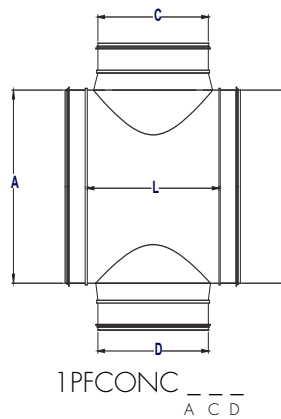

Platinum Flow Specifications

Lateral

Dimensions to be listed as follows: A, B, C
 $L = (1.414 \times C) + 4"$

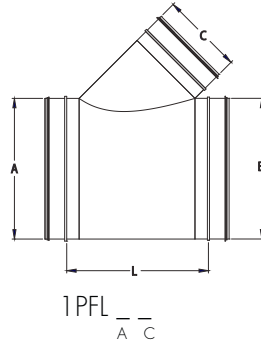

Lateral with Reducer

Dimensions to be listed as follows: A, B, C
 $L = (1.414 \times C) + 4"$

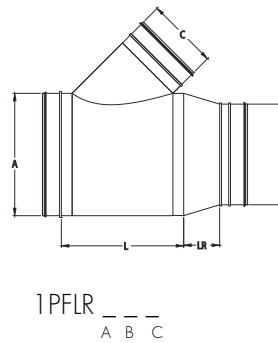

Lateral Cross

Dimensions to be listed as follows: A, B, C, D
 $L = 1.414 \times (\text{larger of "C" or "D"}) + 4"$

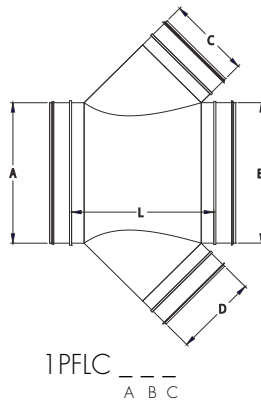

Lateral Cross with Reducer

Dimensions to be listed as follows: A, B, C, D
 $L = 1.414 \times (\text{larger of "C" or "D"}) + 4"$

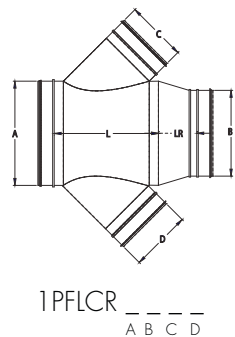

Bullnose Tee (Bullhead)

Dimensions to be listed as follows: A, B, C

1PFTBHT _ _ _
A B C

Y-Branch

Dimensions to be listed as follows: A, B, C

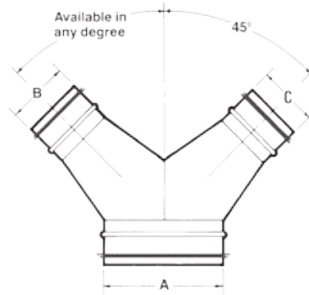

1PFY _ _ _
A B C

Offset

Dimensions to be listed as follows: A, O, L

LR Value for Tees and Crosses

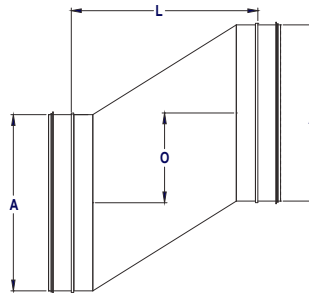

1PFOS _ _ _
A L O

Platinum Flow Specifications

90° Saddle Tap

Dimensions to be listed as follows: A on B

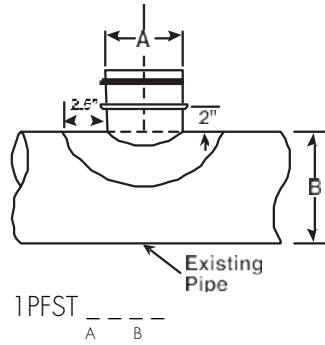

45° Saddle

Dimensions to be listed as follows: A on B

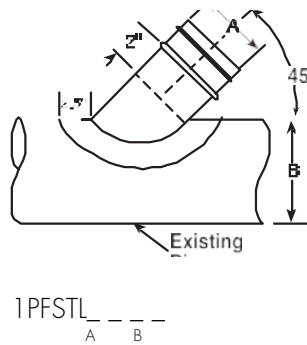

Spiral End Cap (Plug)

Dimensions to be listed as follows:
A, equal diameter



Spiral Coupling

Dimensions to be listed as follows:
A, equals diameter A

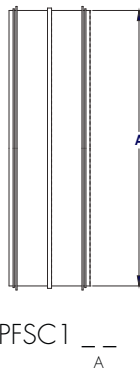

Fitting End Cap

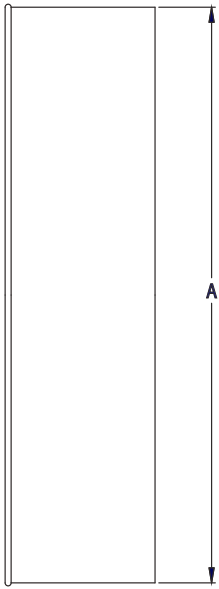

1PFEC2 _ _
A

Fitting Coupling

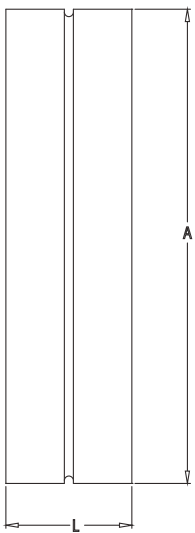

1PFSC2 _ _
A



Platinum Flow Specifications

Concentric Reducer

Dimensions to be listed as follows: A, B
LR = See Chart

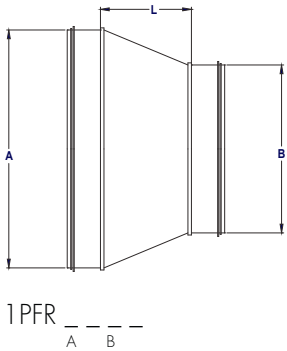

Size Reduction	LR
1	6.5
2 & 3	7.5
4	9.5
5	10.5
6	11.5
7	13.5
8	14.5
9	16.5
10	17.5
11	18.5
12	20.5
13	21.5
14	22.5
15 & 16	25.5
17 & 18	28.5
19	29.5
20	31.5
21	32.5
22	33.5

Eccentric Reducer

Dimensions to be listed as follows: A,B
LR = See Chart

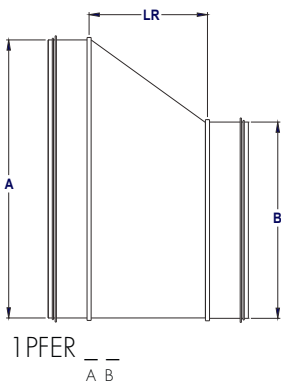

Size Reduction	LR
1	6
2	8.5
3	11
4	13.5
5	16
6	18.5
7	21
8	23.5
9	26
10	28.5
11	31
12	33.5
14	38.5
16	43.5
18	48.5
20	53.5

High Efficiency Take Off

Order as follows: A = Diameter

A	Overall Length
5"	10½"
6"	6½"
8"	7"
10"	7"
12"	7"
14"	7"

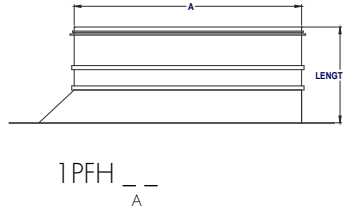

High Efficiency Take Off with Damper

Order as follows: A = Diameter

A	Overall Length
6"	6½"
7"	10"
8"	7"
9"	10¾"
10"	7"
12"	7"
14"	7"

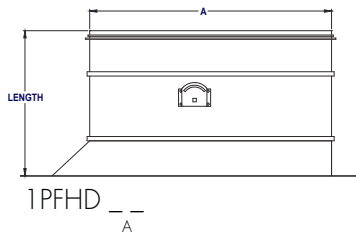

Platinum Flow Specifications

Flat Tap

A = Diameter
4" - 12" - L = 4.625"
14" - 24" - L = 7.375"

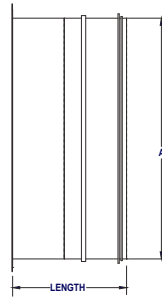

1 PFFT _ _
A



Flat Tap

Order as follows: A = Diameter
Also available with 2" Insulation Extension

A = Diameter
4" - 12" - L = 4.625"
14" - 24" - L = 7.375"

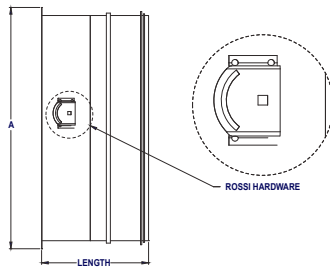

1 PFFTD _ _
A



Flat Tap with Internal Seal

Order as follows: A = Diameter

A = Diameter
4" - 12" - L = 4.625"
14" - 24" - L = 7.375"

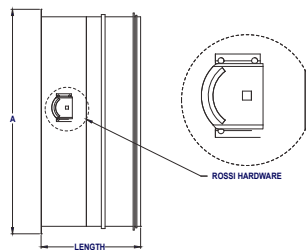

1 PFFTDIS _ _
A



Inline Damper

Order as follows: A = Diameter
 Also available with 2" Insulation Extension

A	Overall Length
5"	5"
6"	5"
7"	5"
8"	5"
9"	5"
10"	5"
12"	7"
14"	7"
16"	7"
18"	10"
20"	10"
22"	10"
24"	10"

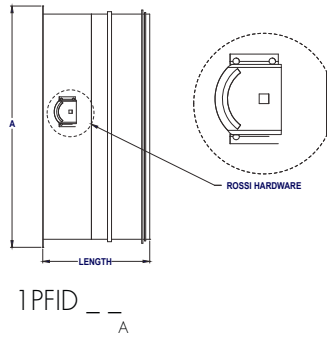

Inline Damper with Internal Seal

Order as follows: A = Diameter

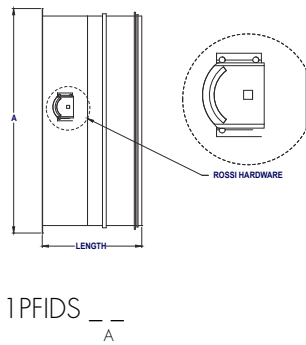

Platinum Flow Specifications

High Induction Diffuser

Engineered high induction diffuser allows de-stratification of the air spaces providing consistency in the temperature, humidity and air density.



1PFDP

The information provided within is for informational purposes only. We have made every effort to ensure the accuracy of the provided information and assume no responsibility for any loss or damage due to errors or omissions or to the use or misuse of any information supplied. It is impossible to test all products under all conditions to which they might be subjected in the field. It is therefore the buyer and/or end users' responsibility to test all products under the conditions that duplicate the service conditions prior to installation. All improvements, all specifications are subject to change without prior notice. It is the buyer and/or end users' responsibility to review our complete **Terms and Conditions of Sale** located on our web sites at: www.novaflex.com | www.z-flex.com | www.flexmaster.com.



HVAC Solutions Specialist



While earning a solid reputation for providing both innovative and high quality products, Flexmaster Canada Limited (part of the Novaflex Group of companies) has proudly supplied superior HVAC products to the construction industry for over 40 years. Combining a variety of patented processes and numerous unique characteristics, an extensive range of superior products are manufactured, with the specified products offering numerous value-added features & benefits.



Flexmaster offers quality products with distinct advantages and excellent value intended to improve system performance as well as enhance overall aesthetics.



Flexmaster Canada Limited is a privately held company committed to continuous advancement in hose and connector solutions. The company has one of the broadest product ranges available in the HVAC marketplace, as well as the Industrial Venting and Hose industries and in Commercial Exhaust Venting Systems. Products are sold in industries across North America and around the world.



For Complete Project Submittal Package, Please Contact

FLEXMASTER CANADA 

20 East Pearce Street, Richmond Hill, ON L4B 1B7
tel: 905.731.9411 fax: 905.731.7086

www.flexmaster.com email: sales@flexmaster.com

